

LOT 3.02				
ORIFICE	INV. "A"	ORIFICE	INV. "B"	GRATE ELEV.
98.20	98.20	98.80	98.20	100.00
2.5"	15"ADS	4.5"	15"ADS	

LOT 3.01				
ORIFICE	INV. "A"	ORIFICE	INV. "B"	GRATE ELEV.
97.00	97.00	97.60	97.00	100.20
2.5"	15"ADS	4.5"	15"ADS	

DETENTION BASIN CROSS SECTION A-A

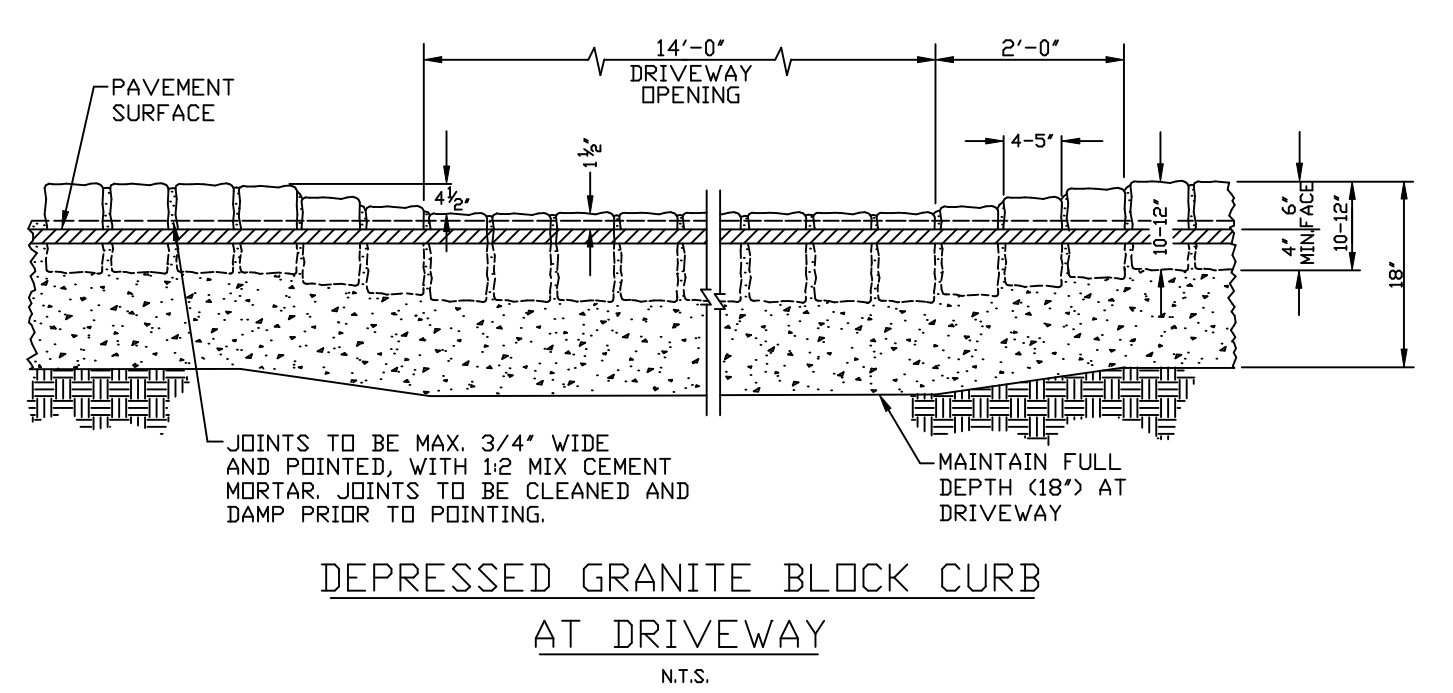
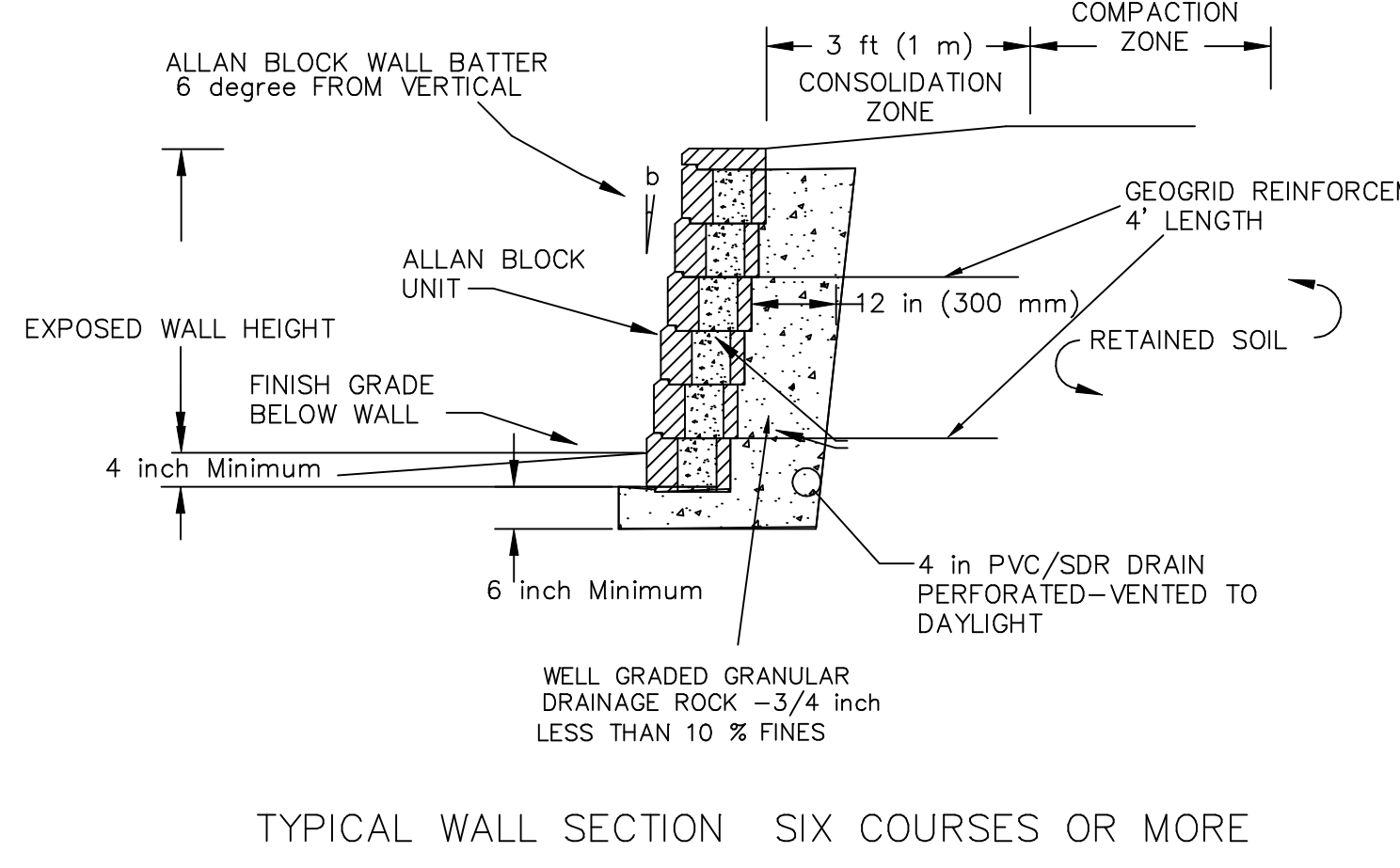
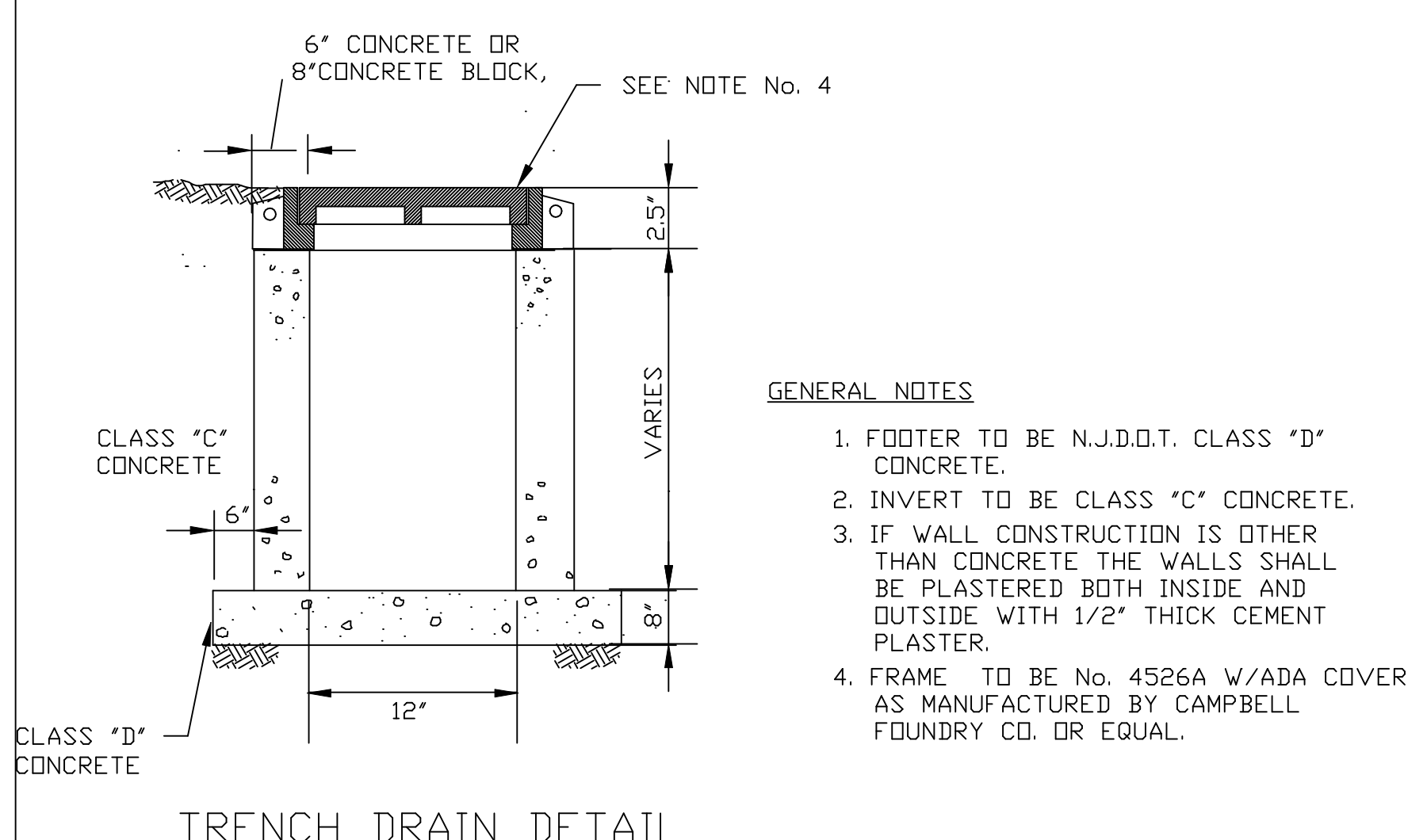
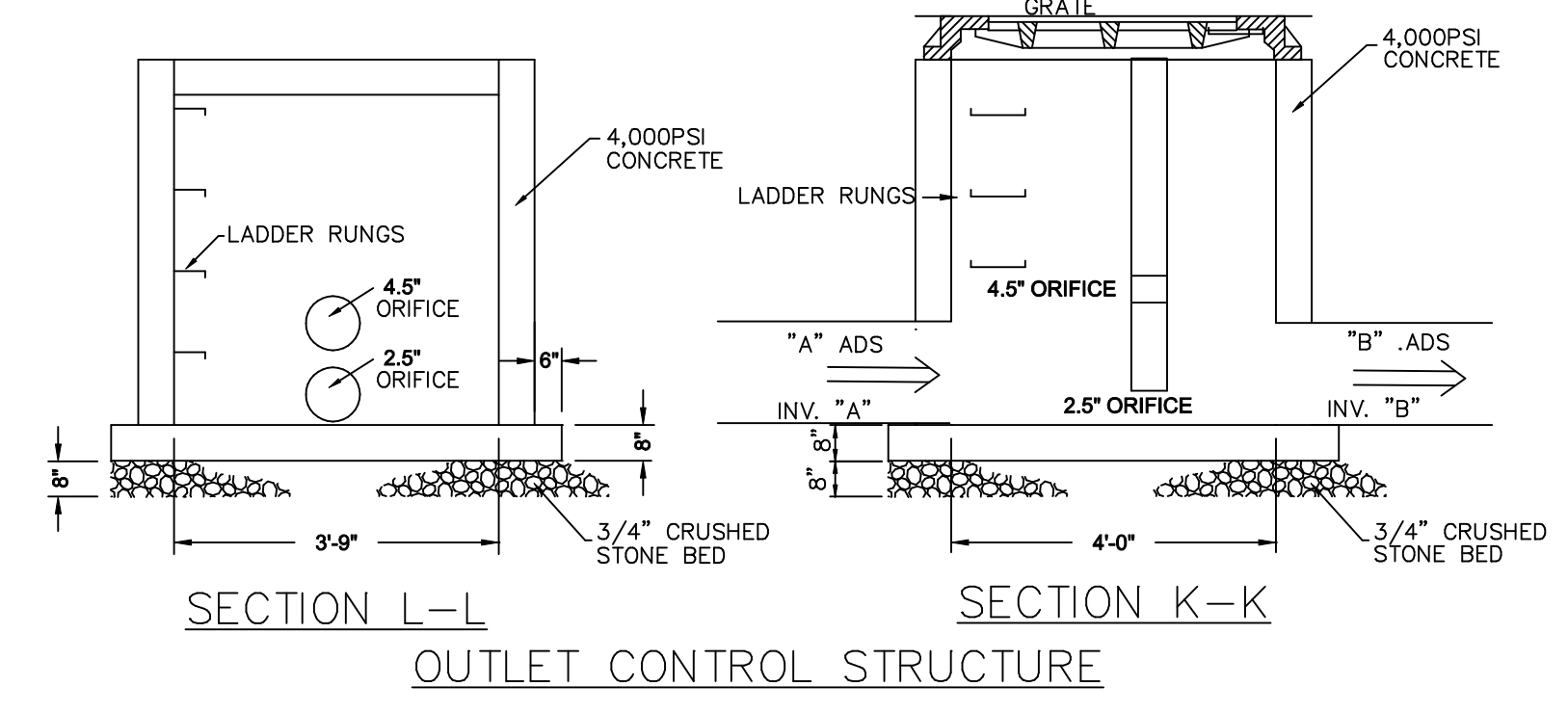
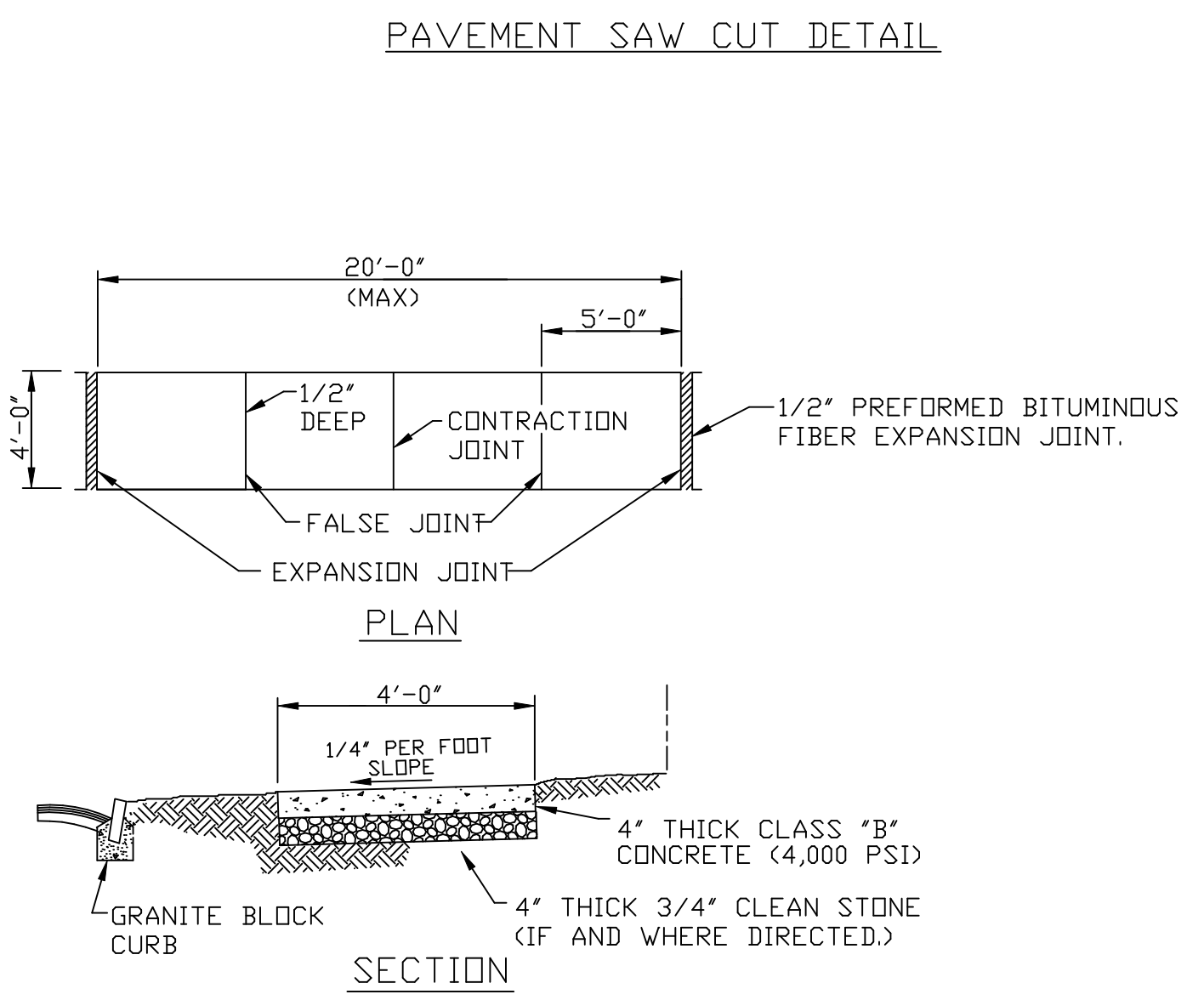
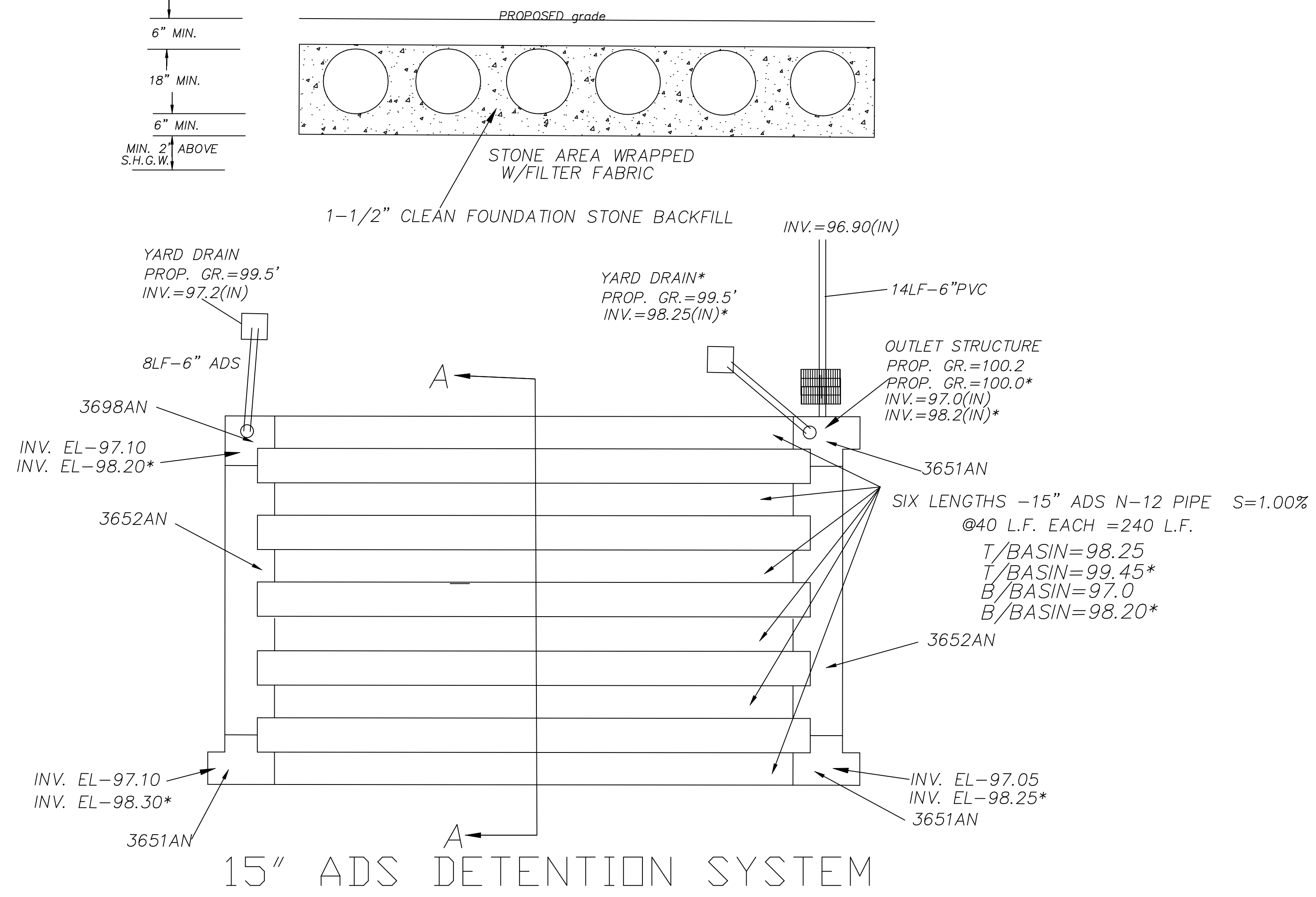

DETAIL SHEET OF
127 BRYANT AVENUE
TOWNSHIP OF CRANFORD,
UNION COUNTY, NEW JERSEY
BEING ALSO KNOWN AS LOTS 1.01, 2, 3 & 4.01, BLOCK 562, TAX MAP SHT. NO. 139, TOWNSHIP OF CRANFORD, UNION COUNTY, N.J.

GUARRIELLO & DEC ASSOC. LLC
CIVIL ENGINEERS AND LAND SURVEYORS
131 NORTH MICHIGAN AVENUE
P.O. BOX 208
KENILWORTH, N.J. 07033
TEL-908-620-1139 FAX-908-620-1102

PREPARED BY: **EDWARD S. DEC**

REVISIONS:
1 June 14, 2021
2 June 23, 2021
3 AUG. 23, 2021

SCALE: 1"=20'
JOB #: B55-15
DATE: FEB. 19, 2021
SHEET NO.: 4 OF 5

N.J. PROFESSIONAL ENGINEER AND LAND SURVEYOR # 24GB03897400
CERTIFICATE OF AUTH. # 24GA28048500