

CRANFORD POOL &
FITNESS CENTER - CENTENNIAL
JOB # 51604

FILTER SYSTEM
AND
ACCESSORIES

SUBMITTAL DOCUMENTS ARE *NOT* TO BE USED FOR INSTALLATION.
PLEASE CONTACT NEPTUNE BENSON FOR AN INSTALLATION
SPECIFIC O&M MANUAL.

ALL RFI QUESTIONS *MUST* BE ANSWERED IN ORDER FOR NEPTUNE
BENSON TO MOVE FORWARD WITH FABRICATION.

ASAP

SUBMITTAL RETURN DATE

SIGNATURE DATE

APPROVAL SIGNATURE OR STAMP

NEPTUNE-BENSON

REQUEST FOR INFORMATION (RFI)

| | | | |
|-------------------------------|------------------------------------|------------------------|---------|
| Neptune Project No.: | 51604 | RFI Number: | 01 |
| Project Name: | Cranford Pool&Fitness Center-Cent. | Date Submitted: | 8/30/23 |
| Cust. Project Manager: | Terry O'Neill | Date Required: | - |
| Project Engineer: | - | Forwarded To: | |
| Contractor: | If It's Water, Inc. | Date Responded: | |

| | | | |
|--------------------------|-----------------------------|------------------------|-----|
| Specification No: | Division 13 & 16 | Page No.: | N/A |
| This RFI is regarding: | General Project Information | Plan Sheet No.: | N/A |
| This RFI requires a: | Standard Specification | Detail: | |

REQUEST:

- Provide the site-voltage specific to the electrical supply/feed for Ultra-Violet sterilization unit(s)
- Confirm facepipe fitting orientation

RESPONSE:

Return completed RFI form direct to renee.hanson@evoqua.com

By:

Signature:

Date:

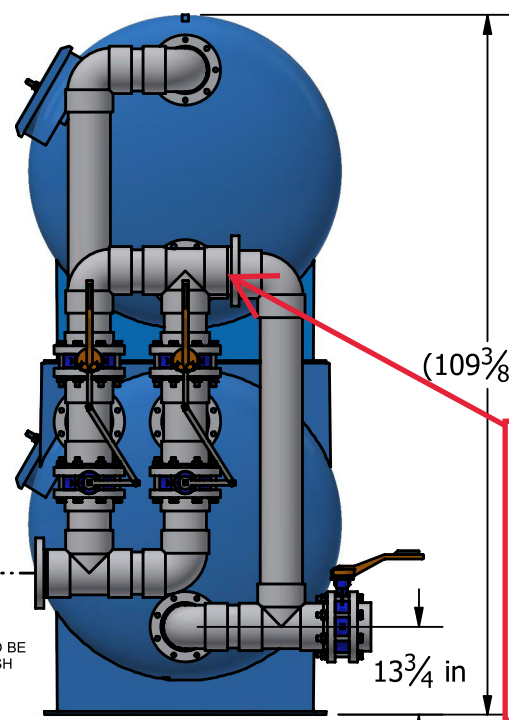
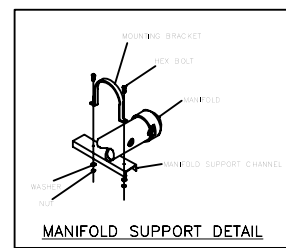
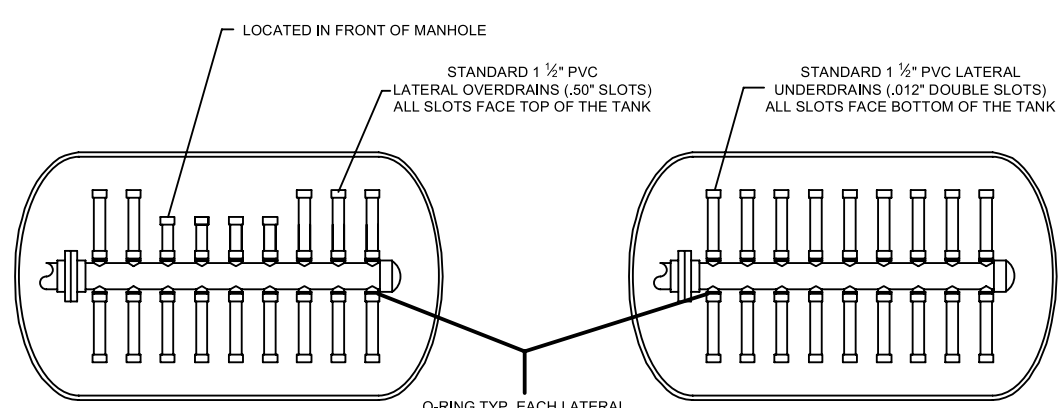
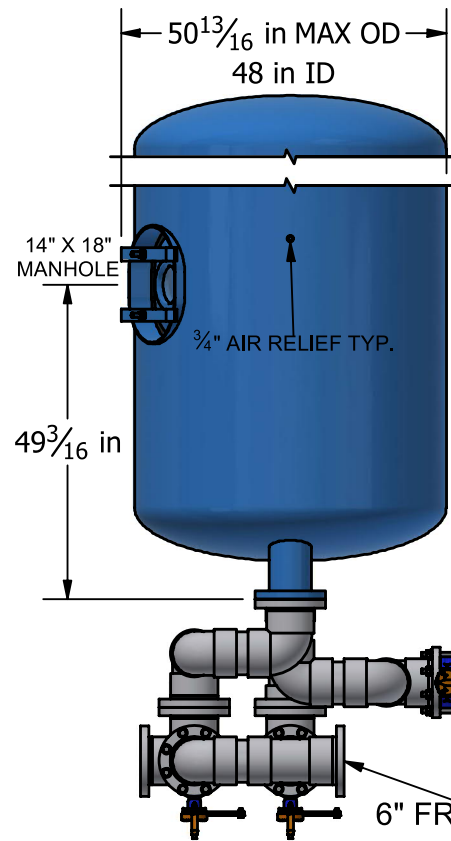

On the face piping drawing I requested to have the center line of the pump inlet raised 12" this submittal does not show it being raised and not having the pump inlet center line dimension from the floor does not tell me there is enough clearance for someone walking under the pipe.

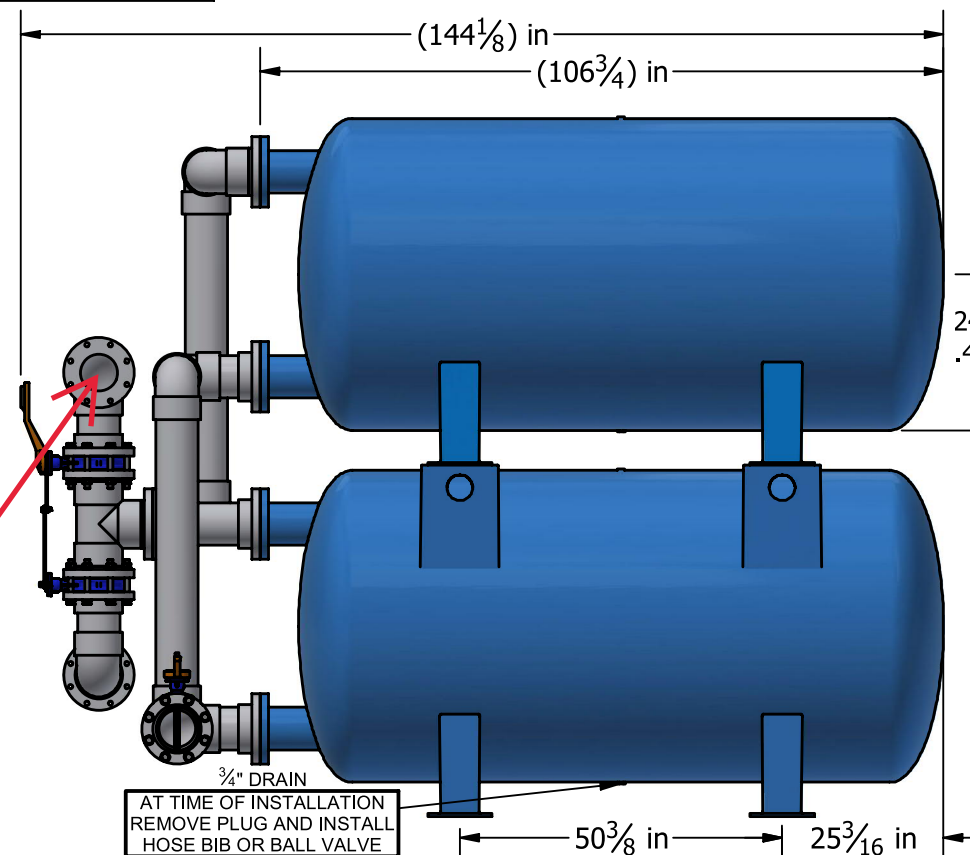

| BILL OF MATERIAL | | | | |
|------------------|------|--|----------------|---------|
| MARK | QTY. | DESCRIPTION | PART # | REMARKS |
| 1 | 1 | HIGH RATE FIBERGLASS FILTER TANK | 4884SHFFGS-6L | NONE |
| 2 | 1 | 6" X 6" SCH. 80 PVC FACEPIPE 3-WAY LEVER OP. | FP2SHFS3WL06X6 | NONE |
| 3 | 1 | 6" BUTTERFLY VALVE LEVER OP. FOR BACKWASH | 516060R037 | LOOSE |
| 4 | 4 | 6" SS BOLTING KIT FLG/FLG | 16006FFCON | LOOSE |
| 5 | 1 | 6" SIGHTGLASS ASSY. | 150156NBSGR1 | LOOSE |
| 6 | 1 | GAUGE PANEL ASSY. | GAUGEPESTR1 | LOOSE |
| 7 | 2 | 6" VERTICAL PIPE MOUNTS | 800UMBKIT6 | LOOSE |

| NOTES |
|--|
| IMPERIAL CONNECTIONS |
| FLANGES CONFORM TO ANSI B16.5, CLASS 150 |
| SEE PLAN VIEW FOR TRUE ORIENTATION OF ALL FITTINGS |
| CUSTOMER TO CONFIRM FILTER TANK WILL FIT THROUGH DOORWAY BASED ON TANK MAX. O.D. |
| DO NOT OVERFILL FILTER WITH MEDIA |
| MANWAYS TO HAVE CLEAR VIEWING WINDOWS |
| SPECIAL NOTES: NONE |

| FILTER DATA |
|------------------------------------|
| SYSTEM FLOW RATE = 630 GPM |
| FILTER AREA = 63.4 SQ.FT |
| FILTRATION RATE = 9.94 GPM/SF |
| SINGLE TANK BACKWASH |
| MIN. BACKWASH FLOW = 476 GPM |
| MAX. BACKWASH FLOW = 634 GPM |
| MEDIA REQUIREMENTS |
| .45mm - .55mm SAND = 49 CU.FT/TANK |
| 4900 LBS/TANK |

- NOTES:
1. FILTER TANK IS CONSTRUCTED OF HIGH STRENGTH FIBERGLASS AND VINYLESTER RESINS WITH ALL EXTERIOR SURFACES IMPREGNATED WITH SPECIAL UV STABILIZERS.
 2. DESIGN PRESSURE IS 50psi, HYDROSTATICALLY TESTED TO 1.1 X WORKING PRESSURE AND DESIGNED WITH A 4:1 SAFETY FACTOR.
 3. UNDERDRAIN AND OVERDRAIN SYSTEMS ARE FACTORY INSTALLED AND SECURED FOR SHIPMENT. USE CAUTION WHEN MOVING TANK TO PREVENT DAMAGE TO THE SYSTEMS.
 4. USE EXTREME CARE WHEN LOADING MEDIA TO PREVENT ANY DAMAGE TO INTERNAL PIPING.
 5. ALL FACE PIPING IS SHOP FITTED, ASSEMBLED AND KNOCKED DOWN INTO SUBASSEMBLIES PRIOR TO SHIPMENT.
 6. USE FLAT WASHERS UNDER BOLT HEADS AND NUTS AT ALL FLANGES.

7. ALL FILTER FACE PIPING SHALL BE SUPPORTED TO PREVENT SAGGING OR BREAKAGE. SUPPORTS ARE NOT SUPPLIED BY NEPTUNE-BENSON. USE INDUSTRY GUIDELINES FOR RECOMMENDED SPACING AND TYPES OF SUPPORTS SEE INSTALLATION AND OPERATION INSTRUCTIONS FOR ADDITIONAL INFORMATION.
8. MEDIA QUANTITIES ARE INDICATED FOR INFORMATIONAL PURPOSES ONLY.
9. IF USING MEDIA OTHER THAN SUPPLIED BY NEPTUNE-BENSON, INC., THE MEDIA MUST CONFORM TO THE REQUIREMENTS OF NSF STD. 50.
10. FILTERS ARE DESIGNED AND CERTIFIED IN ACCORDANCE TO NSF/ANSI STANDARD 50, 5-20 GPM/SQ.FT. RATE
11. TANK(S) IS(ARE) CERTIFIED FOR SEISMIC ZONE 4 RATED

| | | | | |
|--|-------------------------|-----------------|--|--|
| COMPANY CONFIDENTIAL INFORMATION THIS DOCUMENT AND ALL INFORMATION CONTAINED HEREIN, INCLUDING THE DESIGN CONCEPTS AND THOSE ARISING THEREFROM ARE THE PROPERTY OF EVOQUA AND/OR ITS AFFILIATES AND ARE SUBMITTED IN CONFIDENCE. THEY MAY BE USED ONLY FOR THE EXPRESS PURPOSE FOR WHICH THEY ARE PROVIDED AND MUST NOT BE DISCLOSED, REPRODUCED OR COPIED IN ANY FORM, INCLUDING IN ELECTRONIC FORMAT, LOANED OR USED IN ANY OTHER MANNER WITHOUT THE EXPRESS WRITTEN CONSENT OF EVOQUA. ALL PATENT RIGHTS ARE RESERVED. THIS DOCUMENT AND DERIVATIVE WORKS THEREOF ARE PROTECTED UNDER APPLICABLE COPYRIGHT LAWS. UPON DEMAND OF EVOQUA, THIS DOCUMENT, ALONG WITH ALL COPIES AND EXTRACTS, AND ALL RELATED NOTES AND ANALYSES MUST BE RETURNED TO EVOQUA OR DESTROYED, AS INSTRUCTED BY EVOQUA. ACCEPTANCE OF THE DELIVERY OF THIS DOCUMENT CONSTITUTES AGREEMENT TO THESE TERMS. | | DWN BY: M.LYNCH | DATE: 8/30/2023 | TITLE: CRANFORD POOL & FITNESS CENTER-CENTENNIAL INDOOR POOL |
| | | CKD BY: INIT | DATE: | CLIENT: IF IT'S WATER, INC. |
| | | APPD BY: | DATE: | |
| | | MGD BY: | SCALE: | |
| PART NUMBER: - | PROJ/PROD NUMBER: 51604 | CODE: FP | FILE/DRAWING NUMBER: (2)4884SHFFGS-3WL-6X6 | SHEET OF: 1 OF 1 |

| REV | DESCRIPTION | DATE | DWN | CKD | ECN |
|-----|-------------|------|-----|-----|-----|
| - | | | | | |

STD:297x420_A3 v BAR = 25mm AT PLOT SCALE

DOMINION™ BUTTERFLY VALVES NYLON COATED BODY AND DISC

BODY

- Cast aluminum, semi-lug body with flange lug drilling to meet most ANSI 125/150 specifications.
- RILSAN® Nylon 11 coated.
- 2" minimum neck length clearance.

STEM AND DISC

- Through-stem direct drive design requiring no disc screws or pins to connect stem to disc with no possible leak paths in disc stem connections.
- Stem mechanically retained in body neck with corrosion-resistant 304 stainless steel retainer ring.
- Spherically machined, hand-polished disc edge and hub for minimum torque and maximum sealing capability.
- No part of the stem shall be exposed to line media.

SEAT

- Tongue-and-groove seat design with primary hub flat seal and a molded o-ring suitable for weld-neck and slip-on flanges.
- Seat totally encapsulates the body with no flange gaskets required.
- Seat should be interchangeable with all other valve styles of manufacturer.

STEM SEAL AND BUSHING

- Equipped with fixed stem seal and non-corrosive nylon-6 bushings.

PRESSURE RATINGS

- All valves must be factory tested for bubble-tight shutoff to 110% of its pressure rating.
- All valves must be rated bi-directionally to the full pressure rating specified.

MATERIAL SPECIFICATIONS

- **BODY:** RILSAN® - Nylon 11 coated cast aluminum – ASTM B179S12C/DIN 1706AC44100 (2"-12" SIZES)
RILSAN® - Nylon 11 coated ductile iron – ASTM A395M:88/DIN ENJS 1020 EN1563 (14"-16" SIZES)
- **DISC:** RILSAN® - Nylon 11 coated ductile iron – ASTM A395M:88/DIN ENJS1020EN1563
- **STEM:** 420 SS – AISI grade 420
- **SEAT:** EPDM

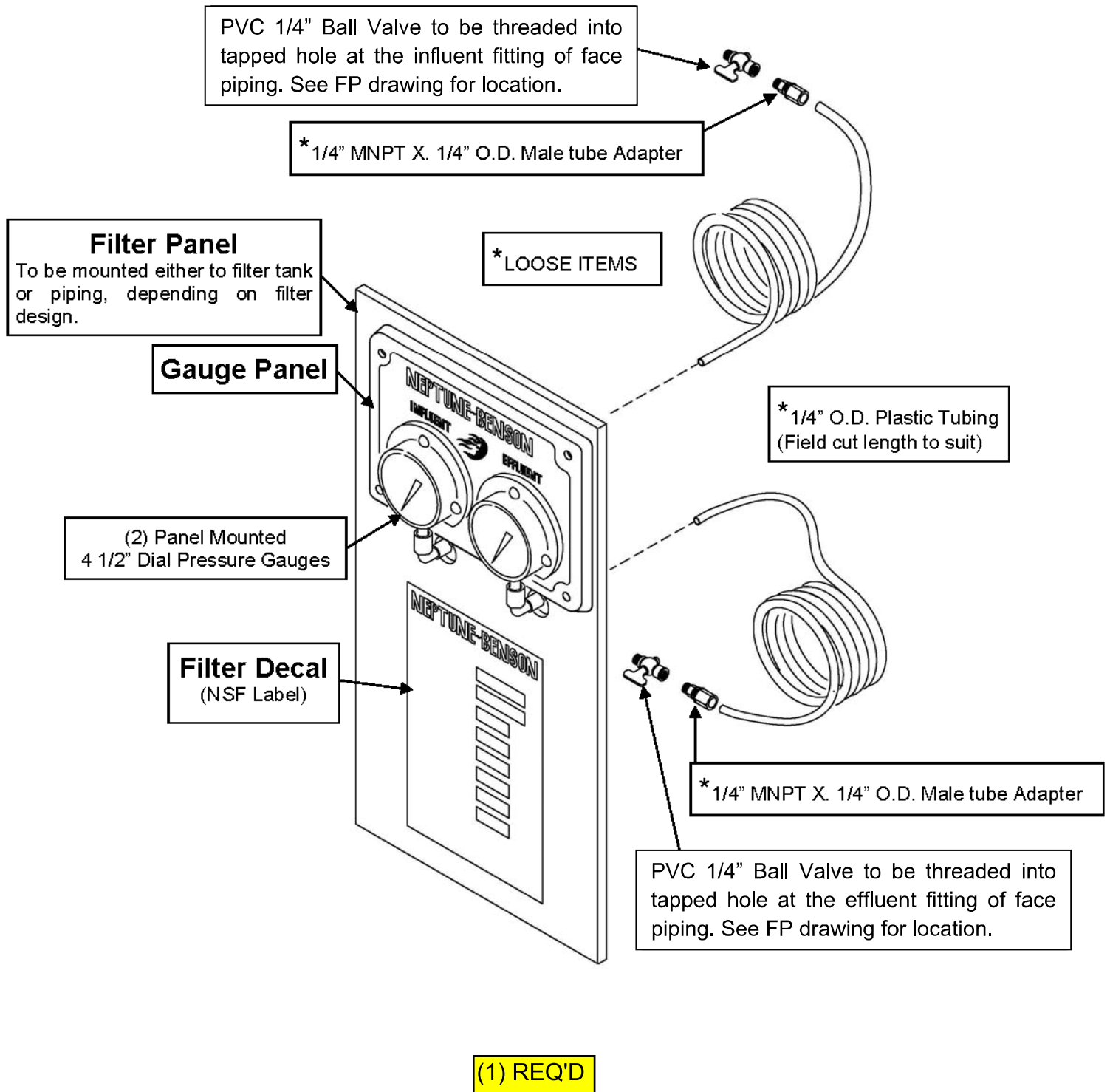

BACKWASH SIGHT GLASS ASSEMBLY & INSTALLATION FOR PIPE SIZES 3" THRU 8"

INSTALLATION INSTRUCTIONS

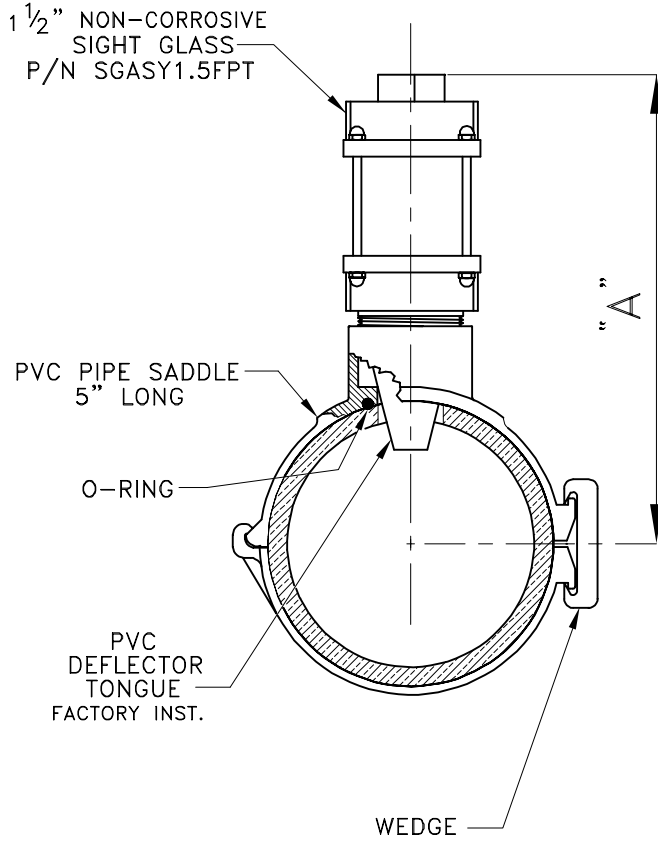

SELECT LOCATION ON THE BACKWASH LINE WHICH WILL ALLOW THE BEST VISIBILITY OF WATER FLOW THROUGH THE SIGHT GLASS .

DRILL A 1 1/4" DIA. HOLE IN THE PIPE. FOR HORIZONTAL PIPING RUNS, DRILL THE HOLE APPROX. 15° ABOVE THE PIPE CENTER LINE TO ALLOW FOR DRAINAGE OF THE SIGHT GLASS.

DRY FIT THE SADDLE AROUND THE PIPE. AT THIS TIME BE SURE THE O-RING IS INSTALLED AND THE DEFLECTOR TONGUE FITS INTO THE DRILLED HOLE AND DOES NOT BIND.

PVC CEMENTING IS RECOMMENDED IF SADDLE IS TO BE INSTALLED IN A PRESSURIZED LINE. INSTALLING CONTRACTOR IS TO DETERMINE IF CEMENTING IS REQUIRED.

INSTALL THE SADDLE SO THAT THE DEFLECTOR TONGUE FITS INTO THE DRILLED HOLE. TAP THE WEDGE OVER THE EXPOSED EARS UNTIL END OF WEDGE IS ALIGNED WITH EDGE OF SADDLE.

(1) 6" REQ'D

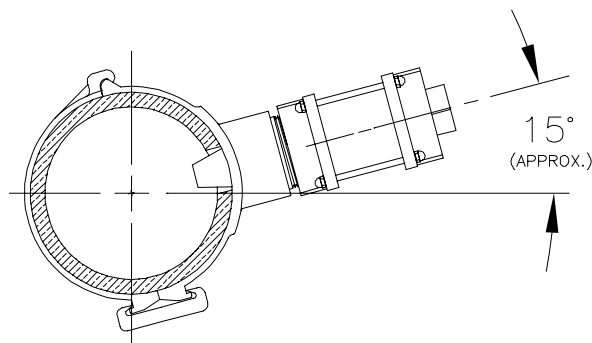

HORIZONTAL INSTALLATIONS

| PIPE SIZE | PART NO. | "A" DIMENSION (APPROX.) |
|-----------|-----------|-------------------------|
| 3" | 1000-6334 | 9 1/2" |
| 4" | 1000-6335 | 10" |
| 6" | 1000-6336 | 11 1/8" |
| 8" | 1000-6337 | 12 1/8" |



The DAV-P-A air relief valve releases entrapped air pockets which accumulate at the high point in the filter or piping systems. Initially, water in the filter or piping raises the valve float and positively seals the specially designed small orifice. During operation, entrapped air rises into the high point of the valve displacing water and lowering the float. This opens the orifice allowing the air to escape. When the air is evacuated, the water again raises the float, resealing the orifice.

(1) REQ'D

| MARK | QTY | DESCRIPTION | PART NO |
|------|-----|-------------------------------|-----------|
| 1 | 1 | 3/4" AIR RELIEF VALVE | 1000-5989 |
| 2 | 1 | 3/4" SCH. 80 PVC THREADED TEE | 1000-6747 |
| 3 | 2 | 3/4" SCH.80 PVC BALL VALVE | 1000-5990 |
| 4 | 1 | 3/4" SCH.80 PVC CLOSE NIPPLE | 1000-6735 |

1

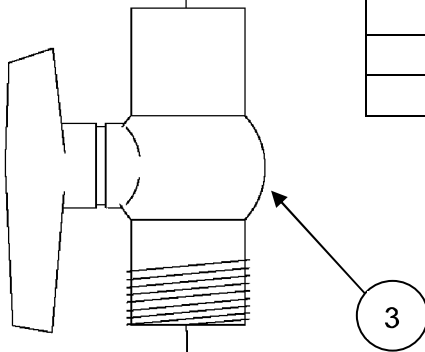

BILL OF MATERIAL FOR ONE ASSEMBLY

ALL ITEMS ARE SHIPPED LOOSE
FACTORY PACKAGED

3 FOR MANUAL AIR RELIEF

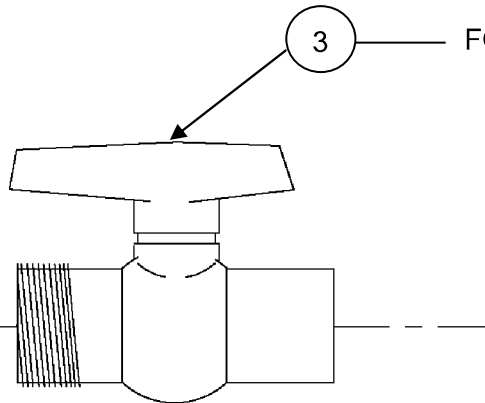

2

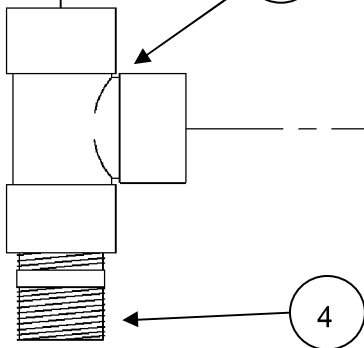

4

AUTO AIR RELIEF FULLY ASSEMBLED HAS A 12 1/2" HEIGHT, TAKE 3/4" OFF FOR THE THREADED PART

4

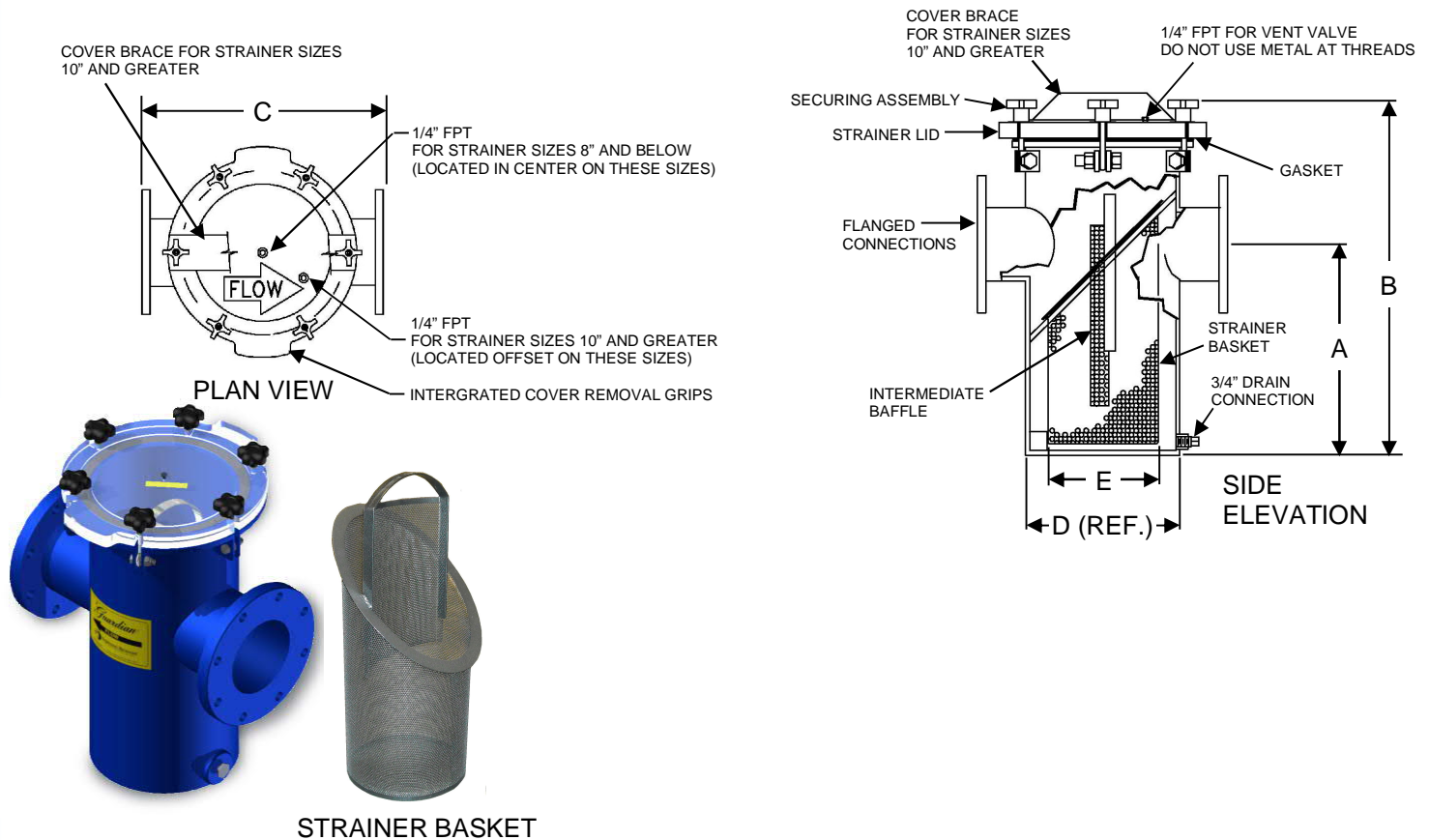

(1) 8" REQ'D w/ SPARE BASKET(S)

| STRAINER SIZE (IN) | STRAINER PART NUMBER | S.S. BASKET PART NUMBER | OPEN AREA OF PIPE (SQ.IN.) | OPEN AREA OF BASKET (SQ.IN.) | RATIO OF OPEN AREA | DIMENSIONS (INCHES) | | | | | MAX. FLOW RATE (GPM) | APPROX. WEIGHT (LBS) |
|--------------------|----------------------|-------------------------|----------------------------|------------------------------|--------------------|---------------------|----|----|--------|--------|----------------------|----------------------|
| | | | | | | A | B | C | D | E | | |
| 3 | 1000-6267 | 1000-8395 | 7 | 117 | 16.7:1 | 8 1/2 | 18 | 18 | 9 1/8 | 5 3/4 | 125 | 45 |
| 4 | 1000-6268 | 1000-8395 | 13 | 117 | 9.0:1 | 8 1/2 | 18 | 18 | 9 1/8 | 5 3/4 | 215 | 45 |
| 6 | 1000-6269 | 1000-8397 | 28 | 210 | 7.5:1 | 13 1/4 | 26 | 20 | 11 1/4 | 7 1/2 | 488 | 75 |
| 8 | 1000-6270 | 1000-8397 | 50 | 210 | 4.2:1 | 12 1/4 | 26 | 20 | 11 1/4 | 7 1/2 | 854 | 80 |
| 10 | 1000-6271 | 1000-8399 | 79 | 515 | 6.5:1 | 21 | 36 | 26 | 16 1/2 | 11 3/4 | 1344 | 155 |
| 12 | 1000-6272 | 1000-8399 | 113 | 515 | 4.6:1 | 20 | 36 | 26 | 16 1/2 | 11 3/4 | 1901 | 170 |
| 14 | 1000-6273 | 1000-8400 | 154 | 694 | 4.5:1 | 22 | 39 | 30 | 18 1/2 | 14 | 2295 | 230 |
| 16 | 1000-6274 | 1000-8401 | 192 | 833 | 4.3:1 | 22 | 39 | 32 | 20 1/2 | 16 | 3012 | 320 |

Strainer body shall be entirely constructed of high strength vinylester fiberglass not less than 1/4" in thickness. All exterior surfaces shall be impregnated with special UV stabilizers. Connections shall be of typical construction with 1" thick fixed flanges. Flanged connections shall be ANSI standard dimensions.

Strainer lid shall be 1" thick transparent acrylic machined to eliminate sharp edges and house securing assemblies. Lid shall be grooved to house rubber gasket. Lid shall be seated with a 1/8" thick, full faced, 40 durometer, neoprene rubber gasket. Strainer lids on units with 10" connections and larger shall include a stainless steel cross brace. Lids shall have integrated cover removal grips.

Basket shall be Type 316 stainless frame and mesh with 5/32" perforations and not less than 52% open area. Open area of basket shall be no less than 4 times greater than the influent connection. Strainer basket shall have a welded intermediate baffle to reduce cleaning frequency. Basket handle shall be 1/8" in thickness.

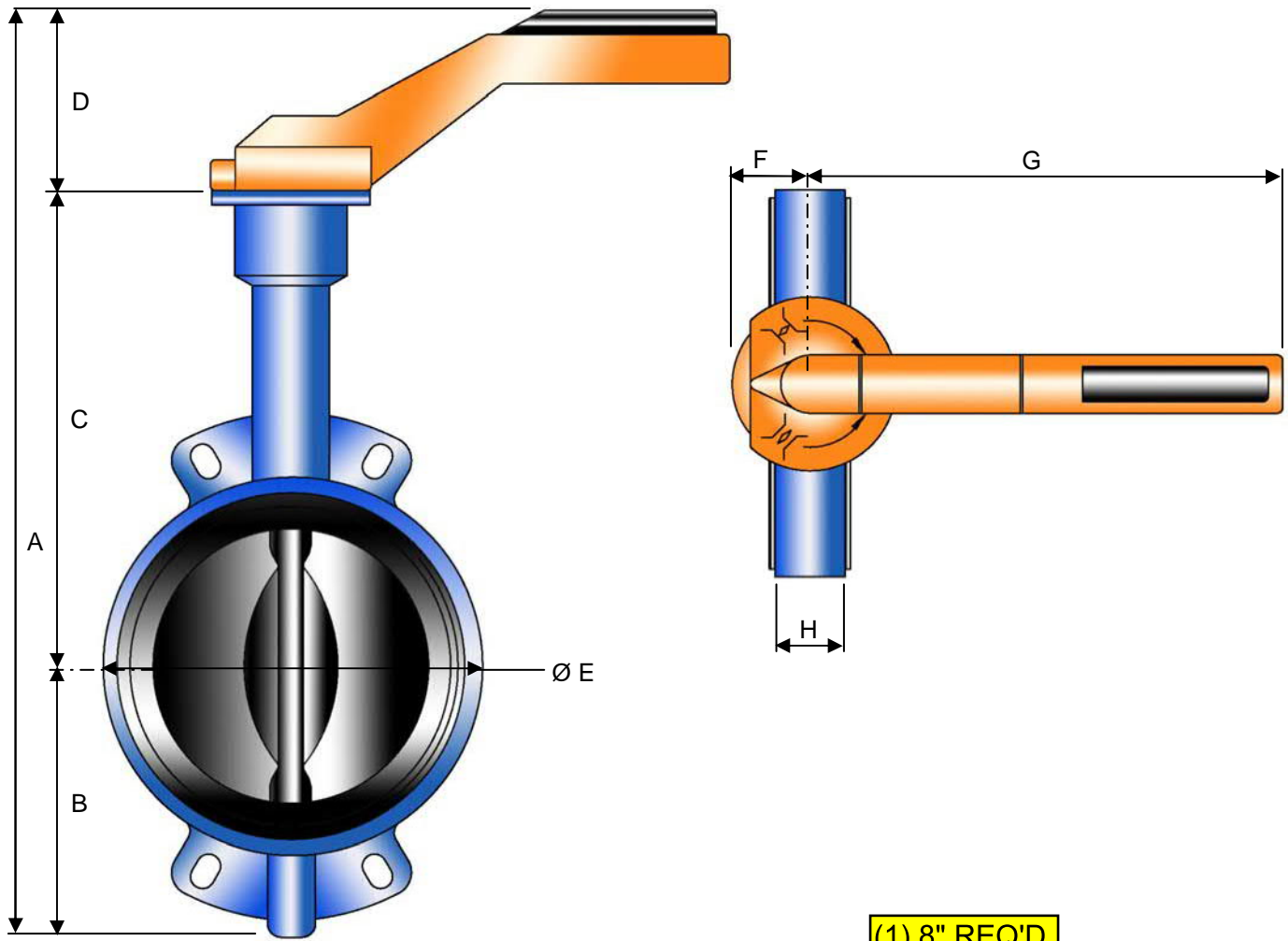

(1) 8" REQ'D
(8) 6" REQ'D

| Part Numbers | | |
|--------------|----------------------|-------------------|
| Size (in) | Stainless Steel Disc | Nylon Coated Disc |
| 2 | 518020RO37 | 516020R037 |
| 2 1/2 | 518025RO37 | 516025R037 |
| 3 | 518030RO37 | 516030R037 |
| 4 | 518040RO37 | 516040R037 |
| 5 | N/A | 516050R037 |
| 6 | 518060RO37 | 516060R037 |
| 8 | 518080RO37 | 516080R037 |

| Size | | Dimensions with hand lever – All dimensions are in inches | | | | | | | |
|-------|-----|---|--------|--------|-------|---------|-------|---------|--------|
| in | mm | A | B | C | D | Ø E | F | G | H |
| 2 | 50 | 11 5/8 | 2 1/4 | 5 1/2 | 3 7/8 | 4 | 1 3/4 | 8 11/16 | 1 3/4 |
| 2 1/2 | 65 | 12 1/2 | 2 5/8 | 6 | 3 7/8 | 4 13/16 | 1 3/4 | 8 11/16 | 1 7/8 |
| 3 | 80 | 13 | 2 7/8 | 6 1/4 | 3 7/8 | 5 1/2 | 1 3/4 | 8 11/16 | 1 7/8 |
| 4 | 100 | 14 1/4 | 3 3/8 | 7 | 3 7/8 | 6 1/4 | 1 3/4 | 12 5/8 | 2 1/16 |
| 5 | 125 | 15 5/8 | 4 1/4 | 7 1/2 | 3 7/8 | 7 7/16 | 1 3/4 | 12 5/8 | 2 1/4 |
| 6 | 150 | 16 7/16 | 4 9/16 | 8 | 3 7/8 | 8 7/16 | 1 3/4 | 12 5/8 | 2 1/4 |
| 8 | 200 | 19 5/16 | 5 7/8 | 9 9/16 | 3 7/8 | 10 5/8 | 1 3/4 | 12 5/8 | 2 3/8 |

CONCENTRIC REDUCERS

Technical Data Sheet

All dimensions are in inches

| Size | Part # | "F" |
|-----------|-----------|-----|
| 3 x 2 | 1000-6165 | 6 |
| 3 x 2 1/2 | 1000-6162 | 6 |
| 4 x 2 | 1000-6175 | 7 |
| 4 x 2 1/2 | 1000-6173 | 7 |
| 4 x 3 | 1000-6181 | 7 |
| 5 x 4 | 1001-9814 | 8 |
| 6 x 2 1/2 | 1000-6369 | 9 |
| 6 x 3 | 1000-6206 | 9 |
| 6 x 4 | 1000-6213 | 9 |
| 6 x 5 | 1000-6221 | 9 |
| 8 x 3 | 1001-9815 | 11 |
| 8 x 4 | 1000-6245 | 11 |
| 8 x 5 | 1000-6251 | 11 |
| 8 x 6 | 1000-6258 | 11 |
| 10 x 5 | 1000-6285 | 12 |
| 10 x 6 | 1000-6291 | 12 |
| 10 x 8 | 1000-6299 | 12 |
| 12 x 6 | 1000-6314 | 14 |
| 12 x 8 | 1000-6321 | 14 |
| 12 x 10 | 1001-9816 | 14 |
| 14 x 8 | 1000-6332 | 16 |
| 14 x 10 | 1001-9817 | 16 |
| 14 x 12 | 1001-9818 | 16 |
| 16 x 8 | 1001-9819 | 18 |
| 16 x 10 | 1001-9820 | 18 |
| 16 x 12 | 1001-9821 | 18 |

(2) 6" X 4" REQ'D



ECCENTRIC REDUCERS

All dimensions are in inches

| Size | Part # | "F" |
|-----------|-----------|-----|
| 3 x 2 | 1000-6168 | 6 |
| 3 x 2 1/2 | 1000-6355 | 6 |
| 4 x 2 | 1000-6178 | 7 |
| 4 x 2 1/2 | 1000-6361 | 7 |
| 4 x 3 | 1000-6185 | 7 |
| 5 x 4 | 1000-6193 | 8 |
| 6 x 2 1/2 | 1000-6371 | 9 |
| 6 x 3 | 1000-6210 | 9 |
| 6 x 4 | 1000-6217 | 9 |
| 6 x 5 | 1000-6224 | 9 |
| 8 x 3 | 1000-6243 | 11 |
| 8 x 4 | 1000-6249 | 11 |
| 8 x 5 | 1000-6255 | 11 |
| 8 x 6 | 1000-6262 | 11 |
| 10 x 5 | 1000-6288 | 12 |
| 10 x 6 | 1000-6295 | 12 |
| 10 x 8 | 1000-6303 | 12 |
| 12 x 6 | 1000-6317 | 14 |
| 12 x 8 | 1000-6324 | 14 |
| 12 x 10 | 1000-6509 | 14 |
| 14 x 8 | 1001-9822 | 16 |
| 14 x 10 | 1000-6517 | 16 |
| 14 x 12 | 1001-9823 | 16 |
| 16 x 8 | 1001-9824 | 18 |
| 16 x 10 | 1000-6524 | 18 |
| 16 x 12 | 1001-9825 | 18 |

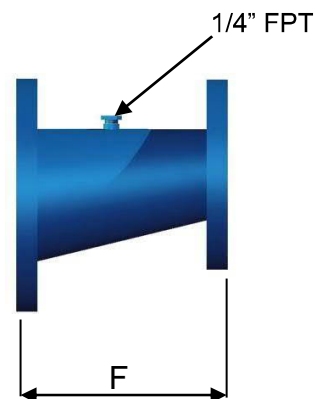

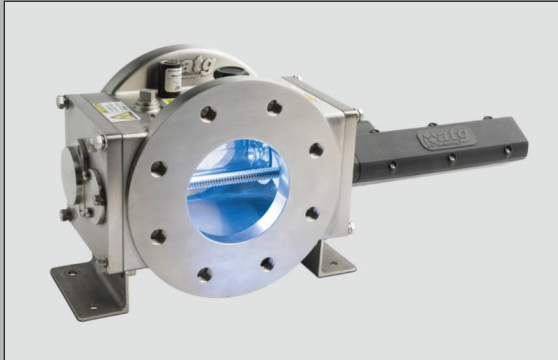

The Wafer™ UV system is the most advanced UV system available. The treatment chamber has been designed for the simplest installation into any pipe work system. The chamber can be mounted vertically or horizontally. The compact design allows existing facilities to be easily upgraded with minimum site work.

TREATMENT CHAMBER

The Wafer™ treatment chambers are designed for installation into the piping after the filters but before chemical injection.

The treatment chamber is manufactured from solid cast 316L stainless steel, with standard ANSI flanged piping connections. Temperature probe, UV monitor probe, and automatic quartz wiper system included.

A pressure rating for the unit is 150 PSI and pressure drop through the chamber is minimal.

Our objective for the product is simple, to be the best on the market, no compromise. The Wafer™ system offers the flexibility of a horizontal or vertical installation application. The Wafer™ product line treats the largest pools with a very compact footprint.

Utilizing our proven medium pressure lamp technology, the Wafer™ system offers a high quality, 'high specifications' product at a very competitive price. The 6" WF-215-6 is suitable for all pools and whirlpools with flows rates up to 810 GPM for indoor applications and 880 GPM outdoors applications.

CONTROL SYSTEM

The control system is housed in a IP 54 rated panel. As a standard, it is supplied with 30 ft cables for connection to the treatment chamber.

The power supply (PSU) and control cabinet are powered with the latest Spectra III microprocessor control unit. Three levels of operation (simple control, full parameter display, and operator configuration) allow for easy, uncomplicated operation of the unit by an operator. The control system features a sophisticated password protected engineering section for integrating the unit with other system devices.

Auto power restart, pump and valve interfaces, process interrupt and low power overnight operation are all features specifically designed for use on all recreational water applications.



WAFER™ UV for Recreational Water



TREATMENT CHAMBER WF-215-6 Technical Data Sheet

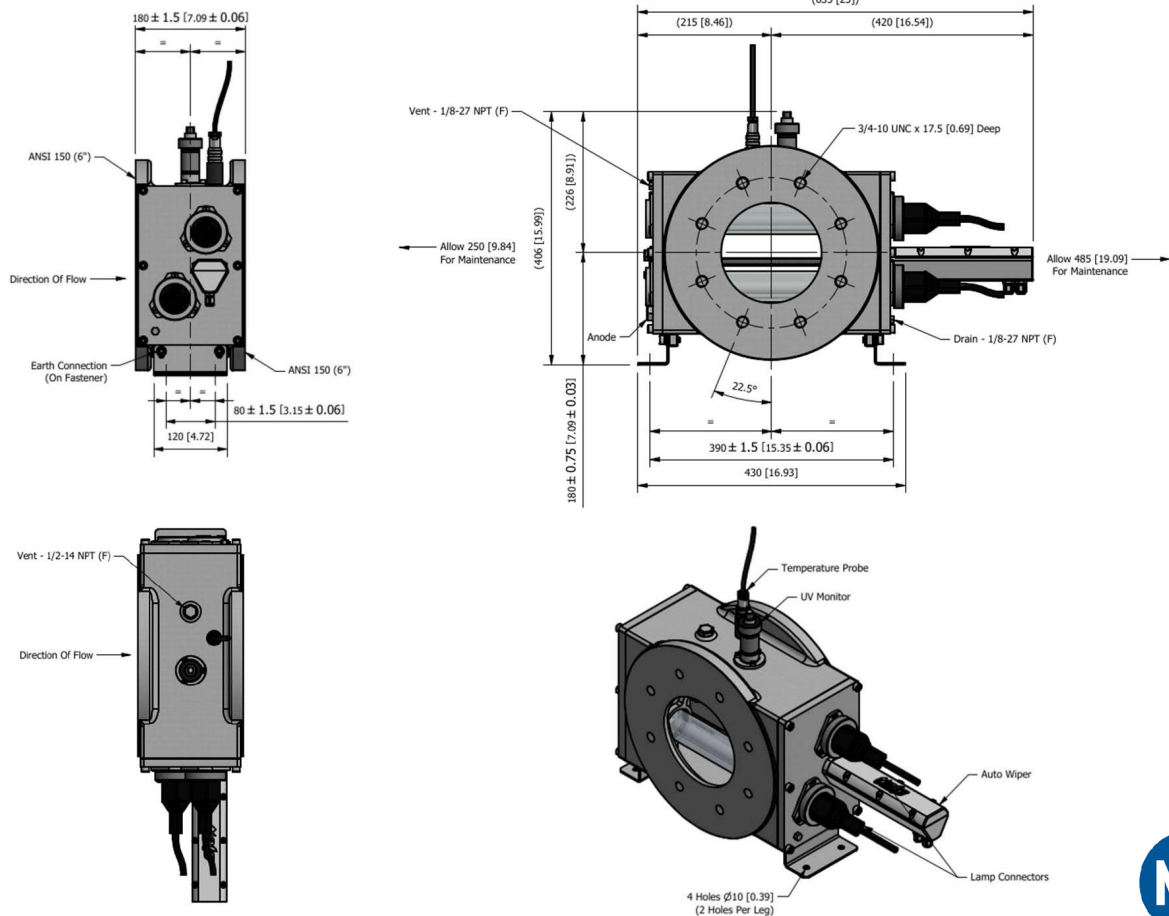

| Type | Lamp & Power | Weight (Dry/Wet) | Connection Size | Sacrificial Anode | Wiper System | Material Construction |
|-------------------------------|--------------|------------------|--|-------------------|--------------|-----------------------|
| WF-215-6 | 2 X 1.5 kW | 128/150 lbs | 6" | 1/2" NPT | Automatic | 316L SS |
| Pressure Rating | | | 150 PSI | | | |
| Drain & Vent | | | 1/8" - 27 NPT Drain 1/2" - 14 NPT Vent | | | |
| Standard Cable Length | | | 30 feet | | | |
| Ingress Protection | | | IP55 | | | |
| GPM for 60 mj/cm2 Dose | | | 810 GPM (indoor) | | | |
| GPM for 40 mj/cm2 Dose | | | 880 GPM (outdoor) | | | |
| Strainer | | | 6" EZ Clean Strainer Included | | | |

Neptune-Benson
EVOQUA

Sales & Service : +1 920-885-4628
www.neptunebenson.com

WAFER™ UV for Recreational Water



CONTROL PANEL WF-125-6 Technical Data Sheet

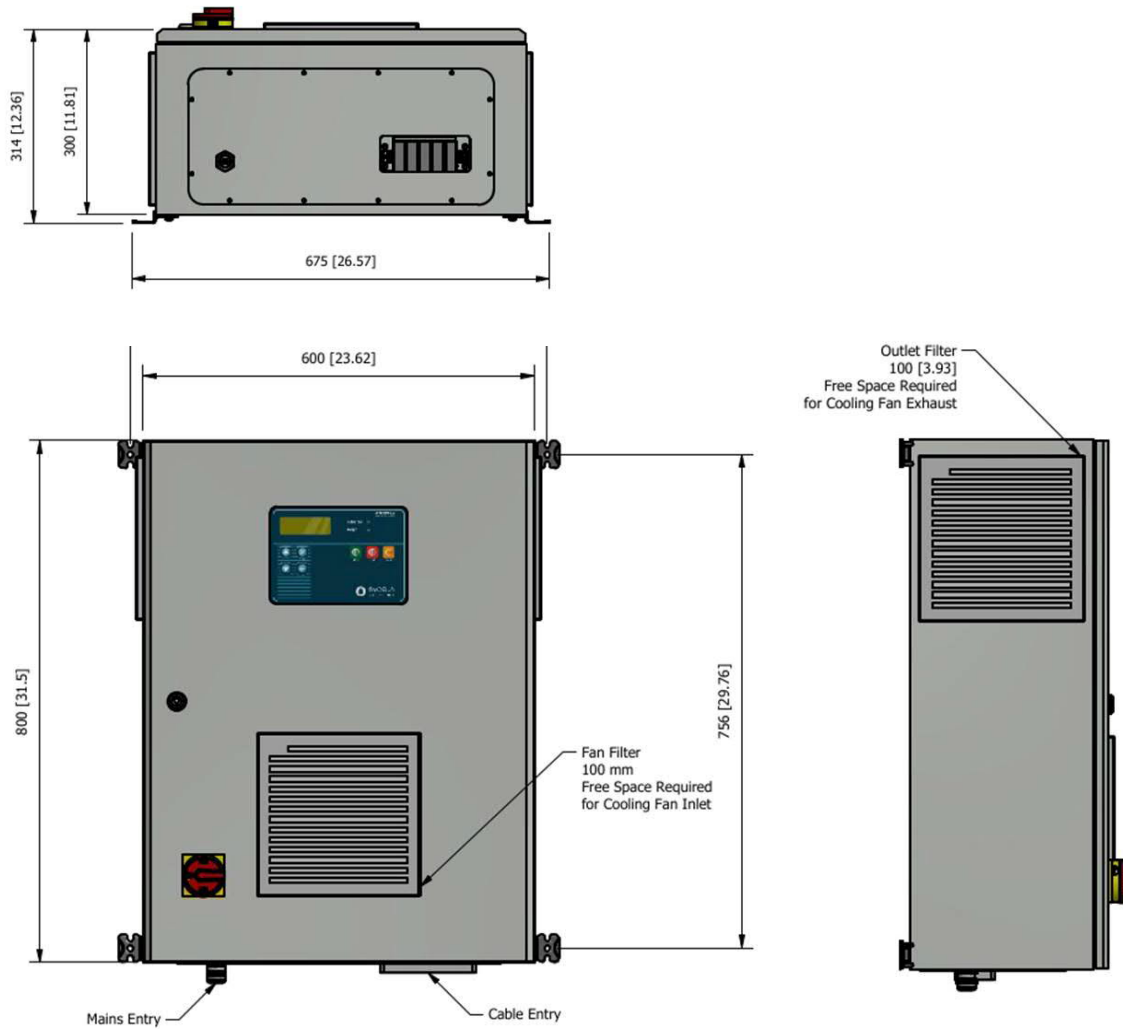

| Type | Lamp & Power | Panel Weight | Breaker Size | Power Supply | Phase | Frequency |
|---------------------------|--------------|--------------|---|--------------|-------|-----------|
| PGA 2x3000 | 2 X 1.5 kW | 110 lbs | 30 Amp | 208-240V | 1 Ph | 50/60 Hz |
| Variable Power | | | 100% to 30% Power (Automatic Dose Pacing) | | | |
| User Interface | | | Spectra Membrane | | | |
| Ventilation | | | Forced Air Cooled (Fan) | | | |
| Ingress Protection | | | IP 54 | | | |